



Platform Fire Hydrant - 2 Nozzle Cast Bronze

Form 12786 - 4/13

Product Features

- UL Listed, FM Approved
- Meets or Exceeds ANSI/AWWA C503
- Bronze Body ASTM B62 UNS C83600
- ASME/ANSI B16.1 Class 125 4" Flange (PN10 & PN16 Optional)
- Individual Stem Operation
- Limited Number of Internal Parts
- Nozzle Threads Conform to NFPA 1963, NH/NST
- Removable Nozzle Design
- Low Zinc Silicon Bronze Stems
- Heavy Duty Disc Holder
- Product Rated up to 250 PSI (1723 kPa), Hydrostatically Tested at 500 PSI (3447 kPa)
- O-Ring Construction in Stem Insert
- Cast Iron Caps (Plastic Caps Available)
- 10-year Limited Warranty



Hydrant Description

Part Number: #J6200
 Nozzle Configuration: 2-1/2" x 2-1/2"
 Flange Pattern: 8 - 3/4" (19mm) Holes, 7" (191mm) DBC

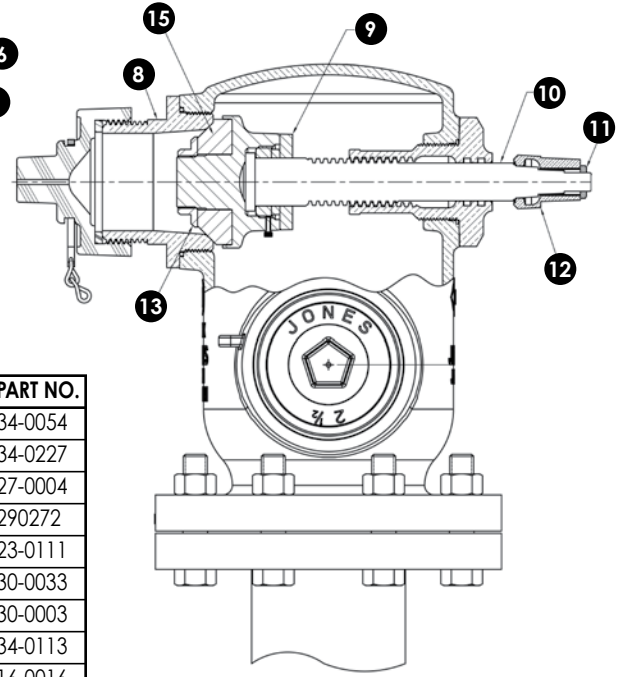
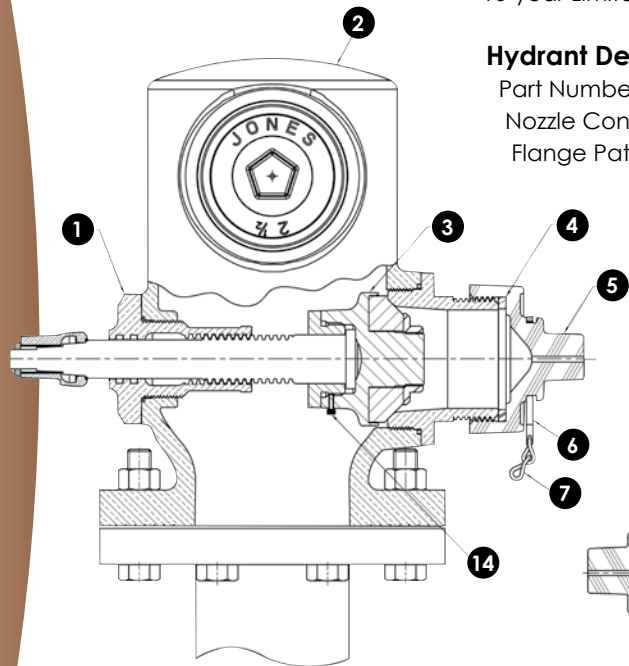

Parts List

ID	PART NAME	MATERIAL	PART NO.
1	Stem Insert - Short	Brass C83600	34-0054
2	Hydrant Body	Brass C83600	34-0227
3	Disc Holder - 2 1/2"	Brass C83600	27-0004
4	Gasket - Cap	Neoprene Rubber	290272
5	Cap - 2 1/2"	Cast Iron	23-0111
6	Chain Ring - 4"	Galvanized Wire	30-0033
7	Chains	Steel	30-0003
8	Nozzle Insert - 2 1/2"	Brass C83600	34-0113
9	Locknut - Stem	Brass C83600	16-0016
10	Stem - 2 1/2"	Brass C87600	26-0089
11	Nut - Stem	Brass C86300	16-0254
12	Nut - Operating	Brass C87600	21-0004
13	Nut - Disc Retaining	Brass C83600	16-0014
14	Screw - Socket Head Cap	Stainless Steel	20-0026
15	Disc	Rubber	28-0010



INTERNATIONAL DIVISION

Dimensions

